

# THREAD RING GAGE LOCKING ASSEMBLY

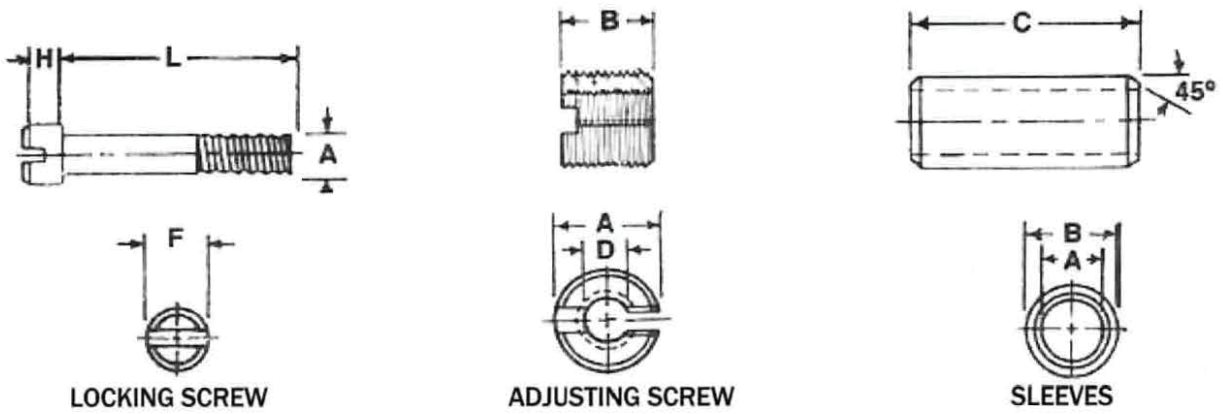

LOCKING SCREW NO.	THREAD RING	A	GENERAL DIMENSIONS				
			F		H		L
			MIN.	MAX.	MIN.	MAX.	
1	1T	#2-64	0.136	0.140	0.066	0.083	29/64
2	2T	#4-48	0.178	0.183	0.088	0.107	23/32
3	3T	#6-40	0.221	0.226	0.111	0.132	1
4	4T	#10-32	0.306	5/16	0.156	0.180	1-1/16
5	5T	#12-28	0.337	11/32	0.178	0.205	1-3/16
6	6T thru 7T	1/4-28	0.367	3/8	0.207	0.237	1-23/64
7	8T thru 10T	5/16-24	0.429	7/16	0.262	0.295	1-23/32
8	11T thru 22T	3/8-24	0.553	9/16	0.315	0.355	2-3/16

SLEEVE NO	THREAD RING	A DRILL SIZE	GENERAL DIMENSIONS		
			B		C +/- 1/64 INCH
			MIN.	MAX.	
1	1T	NO. 43	0.1368	0.1370	1/4
2	2T	NO. 32	0.1808	0.1810	7/16
3	3T	NO. 27	0.2148	0.2150	5/8
4	4T	NO. 10	0.2718	0.2720	11/16
5	5T	NO. 2	0.3337	0.3340	3/4
6	6T thru 7T	F	0.3387	0.3890	13/16
7	8T thru 10T	P	0.4507	0.4510	1-1/16
8	11T thru 22T	25/64	0.5707	0.5710	1-1/2

ADJUSTING SCREW NO	THREAD RING	A EXTERNAL THREAD	GENERAL DIMENSIONS	
			B	D
			+/- 1/64 INCH	
			INTERNAL THREAD	
1	1T	#8-36	3/16	#2-64
2	2T	#12-28	1/4	#4-48
3	3T	1/4-28	5/16	#6-40
4	4T	5/16-24	5/16	#10-32
5	5T	3/8-24	3/8	#12-28
6	6T thru 7T	7/16-20	7/16	1/4-28
7	8T thru 10T	1/2-20	1/2	5/16-24
8	11T thru 22T	5/8-18	9/16	3/8-24

To Order Contact: Gage Crib Worldwide Inc; Email: sales1@gagecrib.com